

Clock Position
 Note: View Clock Position From Inlet End Only

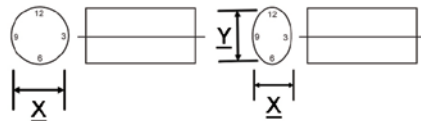

Diameter Note:
 2 measurements required for oval configuration
 X = WIDTH X = 10
 Y = HEIGHT Y = 15

Muffler Info:

OEM Part No.		
Other Numbers		
Muffler Type (1-16)		Other:
Body Diameter	X=	Y=
Body Length (D)		Overall Length (E)
Inlet Diameter (A)	<input type="checkbox"/> ID <input type="checkbox"/> OD	
Outlet Diameter (B)	<input type="checkbox"/> ID <input type="checkbox"/> OD	
Inlet Clock Position		Outlet Clock Pos.
Inlet Offset (F)		Outlet Offset (G)
Length Of Inlet Neck		Length Outlet Neck

Muffler Orientation: Vertical Horizontal Transverse

Muffler Installation Information:

<input type="checkbox"/> Free Standing	<input type="checkbox"/> Cradle Support	<input type="checkbox"/> Flange to Flange
<input type="checkbox"/> Band Straps	<input type="checkbox"/> Mount Brackets	<input type="checkbox"/> Other

Installation Cavity:

X = Width, Y = Height, Z = Length

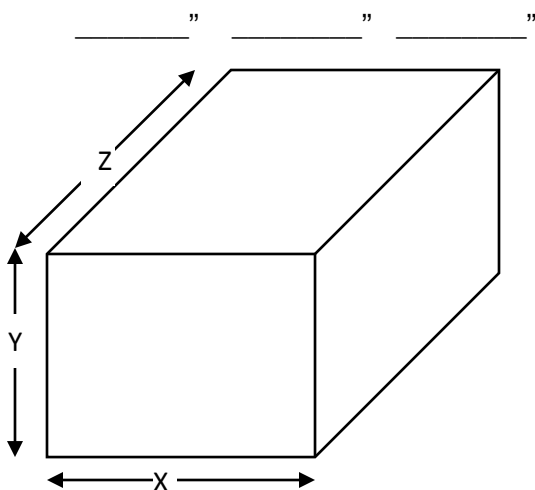

Sketch & Notes Area:

Photo Numbers:

Camera:



Emission Reduction Technologies

718-539-1488
Fax 718-461-6344

Customer Info:

Date:	
-------	--

Company Name:			
Address:			
City, State, Zip:			
Administrative Contact:		Admin Phone	Cell Phone

Installation Location:			
City, State, Zip:			
Installation Contact:		Installation Phone:	Cell Phone:

Vehicle Info:	On Road <input type="checkbox"/>	Off Road <input type="checkbox"/>	Veh Type / Application		
Make / Mfg.		Year		Veh. Model	
Asset #/License Plate		Mileage/Hours		VIN No.	
Engine Mfg.		Engine Year		Engine Model	HP @ RPM
EPA Engine Family		Aspiration	NA - Turbo - TA	No. of Cylinders	Engine Disp.

Sales Rep:		Survey Tech.	
------------	--	--------------	--

Notes
